



ART PAGING & DATA TRANSMITTER



SETUP, INSTALLATION & OPERATING MANUAL



CONTENTS

1	OVERVIEW.....	4
1.1	INTRODUCTION	4
1.2	FIRMWARE AND PROGRAMMING SOFTWARE VERSION	5
1.3	TECHNICAL SPECIFICATIONS.....	6
1.4	APPROVALS AND LICENSING	8
2	CONNECTION DETAILS	10
2.1	CONNECTOR PINOUT	10
2.2	POWER SUPPLY.....	10
2.3	DIGITAL INPUTS 0 & 1.....	10
2.4	DIGITAL INPUTS 3 & 4.....	10
2.5	SERIAL PORT	11
2.6	EXTERNAL ENCODER CONNECTIONS	11
2.7	TEST/PROGRAM ENABLE INPUT	11
2.8	TX LED OUTPUT.....	11
2.9	DEVELOPMENT/PROGRAMMING CABLE.....	11
3	CONFIGURATION & TEST SOFTWARE (P4P).....	13
3.1	OPENING MENU	13
3.2	EDIT PROGRAM	14
3.3	TEST/CALIBRATE.....	18
4	EXAMPLES OF USE.....	20
4.1	AUTO TRIGGER INPUTS	20
4.2	EXTERNAL ENCODERS.....	22
4.3	SERIAL PORT	24
5	SERIAL PORT PROTOCOL	26
5.1	SERIAL PORT AND HANDSHAKING.....	26
5.2	CONTROL CHARACTERS AND DATA FORMATS.....	26
5.3	ERROR MESSAGES.....	27
5.4	CONTROL MESSAGES - FREQUENCY.....	28
5.5	CONTROL MESSAGES - CHANNEL SPACING	29
5.6	CONTROL MESSAGES - POWER LEVEL	29
5.7	CONTROL MESSAGES - MODULATION TYPE	29
5.8	CONTROL MESSAGES - COMPATIBILITY NUMBER.....	31
5.9	TRANSMIT DATA FORMATS	31

1 OVERVIEW

1.1 INTRODUCTION

The ART paging and data transmitter is a small, rugged, purpose built UHF synthesised paging transmitter for on-site applications. The unit provides a combined digital and analogue paging solution via external encoders, closing contacts or the RS232 port provided. Ideally suited for industrial alarm and commercial site paging, where a fast response to a problem or situation is essential. Typical applications include; Fire, Security, Medical, Shopping centres, Airports, Process and plant control, PLC systems, and SCADA applications.

Communication to the transmitter via the RS232 port uses a relatively simple protocol which is outlined in section 4, this protocol is compatible with the Communique CPT450 paging transmitter and the ART400T will replace this device successfully in most applications, the device can be also be programmed to be compatible with SCOPE products. (SCOPE is the trademark of SCOPE ELECTRONICS Ltd, Communique is a trademark of Pacscom Ltd.).

The ART400T contains some improvements over the Communique CPT450 as follows:

1. Pocsag baud rates extended to include 2400 baud.
2. Increased buffer sizes allow messages of up to 500 characters to be sent.
3. Stored message sizes increased to 80 characters.
4. Scope mode can now be entered from POCSAG Text protocol and escaped again.
5. Increased buffer size allows CTS flow control to be ignored, RTS handshaking is no longer required.
6. I²C bus digital input expansion available.

Incompatibilities are as follows:

1. 25 way "D" connections are not the same, please refer to the pinout listing.
2. Digital inputs can be used as auto trigger inputs or as PTT inputs but not both at once. When configured for four trigger inputs, inputs 0 & 1 have internal pull-ups, but inputs 2 and 3 require external pull-up to a positive supply if being driven from open collector or voltage-free relay contacts.
3. It is not possible to connect an external analogue and an external digital encoder at the same time without observing some special precautions.

PAGERS SUPPORTED

The transmitter will support almost any digital/analogue pager or mixture of pagers. This enables easy upgrades without the user being tied to one pager manufacturer.

INDUSTRIAL ALARM APPLICATIONS

For industrial applications the paging transmitter can be coupled to a PC, PLC, or alarm panel via the RS232 port, the host can then page the relevant pager or group of pagers with an alert tone, numeric or alphanumeric message that relates to the alarm or system status.

For simplified applications two closing contact inputs have been provided, each can be programmed via the P4P software with the pager or pager group ID and a message for transmission. In addition the frequency, channel spacing, modulation type and power level required can be included. Should more than two be required expansion cards can be connected to the I²C bus interface.

COMMERCIAL APPLICATIONS

For commercial office and factory paging applications the ART transmitter can be used with almost any digital/analogue encoder or with proprietary software packages.

PC PROGRAMMING

The P4P programming software can be used to re-align the paging transmitter after service/repair or to programme frequency, RF power, channel spacing and input levels. The programmed information can then be stored to disc with the client's details for future use.

EASY SERVICE AND MAINTENANCE

In the unlikely event of a transmitter failure the programming facility allows a replacement to be programmed and installed in a matter of minutes, the defective unit may then be removed for repair.

BUILT IN ENCODING SOFTWARE

The ART transmitter has built in encoding software for POCSAG and five/six tone selcall formats. The encoding software is accessible via the RS232 port and the two switched inputs. If additional encoding software is required for new or different formats it can be easily incorporated at minimum cost.

LICENSING

The ART transmitters meets the European requirements for both licence-exempt and licensed applications under EN300-220 and EN300-224/113 respectively. The user must ensure that the radio modem is used under the terms & conditions applicable to the use of the bands concerned. In licensed bands, the user must obtain permission and the necessary licences from the relevant authorities. The ART400T version of the radios is also FCC and IC certified for use in the USA and Canada.

1.2 FIRMWARE AND PROGRAMMING SOFTWARE VERSION

At the time of writing this update to the manual, the transmitter firmware was at version 4.7 and the P4P set up program was at version 6. Older or newer versions of the firmware or the configuration software may have slightly different features available.

1.3 TECHNICAL SPECIFICATIONS

General:

Frequency Ranges:	ART170	138 - 175MHz
	ART225	175 - 250MHz Special Order only
	ART280	260 - 285MHz Special Order only
	ART320	320 - 340MHz Special Order only
	ART400	402 - 512MHz
	ART900	800 - 950MHz Special Order only
Programmable bandwidth:	12MHz	
Power Requirements:	9.6 - 15VDC	
Channel Spacing:	Programmable 12.5/20/25 kHz	
Operating Temperature:	-30°C to +60°C.	
Frequency Stability:	2ppm over operating temperature range.	
Enclosure:	Milled Aluminium	
Size:	102mm W x 130mm L x 45mm H	
Weight:	600g	
Connectors:	Interface: 25 way "D" plug	
	Antenna: BNC	
	Power: 2 way pluggable terminal block	
	I2C bus: 10 way RJ45	
R.F. Output Power:	50mW - 5W programmable.	
Max Deviation:	±7.5kHz.	
Adjacent Channel Power:	Better than 70dB at 25kHz	
Spurious Emissions:	As per ETS approval requirements	
Rise Time	< 10ms	

Inputs:

Serial:	5VTTL or RS232
External Mod Input Levels:	Digital: threshold -7.5 to +12.5VDC Analogue: 300mV to 5Vpeak to peak.
Closing contacts:	Two inputs as standard. Models manufactured after May 2007 can optionally be configured for four input operation. Each contact is programmable with frequency, power, pager ID/Group and a stored message. In 2 input mode, maximum message length is 80 characters. In 4 input mode, this reduces to 40 characters. Number of inputs is expandable to 128 inputs in blocks of 8 with external expansion modules

Internal Encoder:

Pagers Supported:	Tone, Numeric, Alphanumeric.
Built in Encoding Software:	POCSAG 512, 1200 & 2400bps ERMES & FLEX under development
Selcall formats:	CCIR, EEA, EIA, ZVEI, ZVEIS, ZVEID, ZVEIP with programmable lengths of 33, 40, 70 & 110mSec.
Optional Data formats	FFSK, V23, BELL202 up to 1200bps 2400 using coherent 1200/2400bps GMSK at 4800bps & 4 level FSK at 9600bps
Custom Formats:	Available on special order.

In the interest of product improvement, all specifications are subject to change without notice.

1.4 APPROVALS AND LICENSING

The ART Paging and Data Transmitter has been designed to meet the relevant standards outlined below. Should other approvals be required, please contact the sales office.

1.4.1 European Approvals

ETS 300-220	The units meet the specification for European license-exempt communications with a maximum RF power level of 500mW. Please note that permitted power level may vary from country to country.
ETS 300-224	The units meet the European specification for On-Site Paging Services.
ETS 300-113	The units meet this specification for licensed data radios
ETS 301-489:	The units meet the required CE specification and carry a CE Mark.
EN60950	The units meet the relevant requirements of this Safety specification.

1.4.2 European Declaration of Conformance

Hereby, RF DataTech declares that the ART Range of Paging and Data Transmitters is in compliance with the essential requirements and other relevant provisions of Directive 1999/5/EC.



1.4.3 USA FCC Part 90 & 15 & Canadian RSS-119 (Only applies to ART400T-5 version)

FCC ID: P8W-ART400
IC: 4264A-ART400

The ART400T-5 transmitter has been tested and found to comply with the limits for a Class A digital device, pursuant to Part 15 of the FCC Rules. These limits are designed to provide reasonable protection against harmful interference when the equipment is operated in a commercial environment. This equipment generates, uses, and can radiate radio frequency energy and, if not installed and used in accordance with the instruction manual, may cause harmful interference to radio communications. Operation of this equipment in a residential area is likely to cause harmful interference in which case the user will be required to correct the interference at his own expense.

 **WARNING:** Changes or modifications not expressly approved by RF DataTech could void the user's authority to operate the equipment.

This device complies with Part 15 of the FCC Rules. Operation is subject to the condition that this device does not cause harmful interference.

RF EXPOSURE

 **WARNING:** To satisfy FCC/IC RF exposure requirements for mobile transmitting devices, a separation distance must be maintained between the antenna connected to this device and persons during device operation. To ensure compliance, operations at closer than these distances are not recommended. The following table show the minimum distance for different gain antennas:

Antenna Gain	Minimum Separation Distance
Unity or Less	0.5m
3dB	0.7m
6dB	1.0m
8dB	1.3m
10dB	1.6m
12dB	2.0m

The antenna used for this transmitter must not be co-located in conjunction with any other antenna or transmitter

This device has been designed to operate with external antennas having an impedance of 50 ohms.

To reduce potential radio interference to other users, the antenna type and its gain should be so chosen that the equivalent isotropically radiated power (EIRP) is not more than that required for successful communication and is not higher than permitted levels.

2 CONNECTION DETAILS

2.1 CONNECTOR PINOUT

Connections to the unit are made via the 25 way "D" plug whose pins are allocated as follows; for connections required in specific applications refer to the applications examples later in this manual. Note that power can be supplied to the unit either using the 25 way D connector or the 2 way terminal block.

pin 13	+12V power input (internally connected to terminal block power input)
pin 25	power input ground (internally connected to chassis)
pin 14	digital input 0 (Auto trigger input 0 / Analogue external encoder PTT)
pin 15	digital input 1 (Auto trigger input 1 / Digital external encoder PTT)
pin 1	shield ground (internally connected to power ground)
pin 2	TXD
pin 3	RXD
pin 4	RTS (or Auto trigger input 2 when configured for 4 inputs)
pin 5	CTS
pin 6	DSR
pin 20	DTR (or Auto trigger input 3 when configured for 4 inputs)
pin 7	RS232 ground (internally connected to power ground)
pin 24	External analogue/digital encoder DC coupled input
pin 12	External analogue encoder AC coupled audio input (connect the ground line for these two signals to pin 25)
pin 9	Program Enable
pin 18	TX led output
pins 8,10,11,16,17,19,21,22,23 not used	

2.2 POWER SUPPLY

The power supply should be a smoothed supply of 9.6 to 15VDC capable of supplying 3.0 amps.

2.3 DIGITAL INPUTS 0 & 1

The digital inputs can operate as auto trigger inputs providing a means of sending stored messages to pagers without using the serial port or external encoder. The two lines may be set up to send a different message to a pager, different pager types and frequencies can also be set up for each line. The digital inputs are internally pulled up to +5V, external contacts or open collector devices can pull these inputs to 0V to trigger transmission. Once triggered no further transmission will take place unless the trigger line is first brought high and then low again. Note that these lines also serve as the PTT inputs for external encoders, the trigger inputs are disabled when the device is programmed for external audio operation.

Note that the stored messages will not operate if the serial port is configured for SCOPE protocol mode.

2.4 DIGITAL INPUTS 3 & 4

When the unit is configured for 4 input operation (option only available in versions manufactured after May 2007), digital inputs 2 and 3 use the pins otherwise allocated as RTS and DTR. The RTS and DTR lines cannot be used when 4 input mode is selected. Unlike inputs 0 & 1, the optional inputs 2 & 3 are not internally pulled-up to any positive supply and they must therefore be driven by a voltage source (0V or +5V) or have external pull-ups fitted to allow use of dry contacts or open collector inputs. The ART can cope with these inputs being pulled up to the +12V line through a resistor (10k ohm is generally suitable) but, if doing so, care should be taken to ensure that the

external driving circuit can handle exposure to this voltage. If pulling up to an external 5V line, then a pull-up resistor value of 2.2k ohm is more suitable.

Note that the stored messages will not operate if the serial port is configured for SCOPE protocol mode.

2.5 SERIAL PORT

The connections RXD, TXD, CTS, and RS232 ground make up all that is needed to connect to the transmitter's serial port. Standard RS232 level signals must be used with the port. RXD and TXD are the serial data lines, CTS is a flow control line not needed for most applications, RXD and CTS are outputs, TXD is an input. RTS, DSR and DTR need not be connected.

2.6 EXTERNAL ENCODER CONNECTIONS

Two types of external encoder are catered for, analogue types having FFSK, Selcall, or two tone audio outputs or digital types having logic level outputs. Two signal inputs are provided for either AC or DC coupled operation, only the DC input may be used as a digital input, either input may be used for analogue operation. When used as a digital input the DC coupled path has a programmable logic threshold value between +7.5 and -12.5V. When used with a digital input the transmitter takes in the signal and reconstitutes the data as internally generated modulation, in analogue operation the signal is passed through limiting and filtering circuits for direct application to the transmitter modulation input. Note that if the DC coupled input is used in analogue mode the applied signal must be centred around 2.5V or an offset in the frequency of the transmitted signal will result. Use of the DC coupled input is desirable when the applied signal has heavy DC components, this is true of POCSAG or direct FSK type signals.

External encoders can be connected to the transmitter and used at the same time as the serial port for transmission. The input audio level for analogue operation can be programmed using the PC set-up programme, note that the frequency response characteristic of the paging transmitter is flat and not emphasised. The digital encoder data input can be programmed to operate with various logic levels e.g. TTL, RS232 or other.

2.7 TEST/PROGRAM ENABLE INPUT

When grounded this input puts the transmitter into a mode where testing or programming using the PC set-up program can take place, during normal operation leave the input open circuit.

2.8 TX LED OUTPUT

The anode of an external transmit led can be connected between this pin and ground to give remote indication of transmission. When on the output supplies 5V via a 1.15k ohm resistance which yields about 3mA for a LED dropping 2V, it is therefore advisable to use a low current type led.

2.9 DEVELOPMENT/PROGRAMMING CABLE

For development purposes it is useful to have a cable made up that allows the transmitter to communicate with a PC comms port, and also be switched in and out of test/program mode. A suitable cable can be made up as follows, 3 cables should come out of the transmitter connector, one for the PC, one for the power supply, and one for a test/program enable switch;

The wiring schedule for the cable is shown below: The connectors required are a 25 way "D" socket and a 9 way "D" socket, the switch can be any on/off type where the on/off states are easily distinguishable.

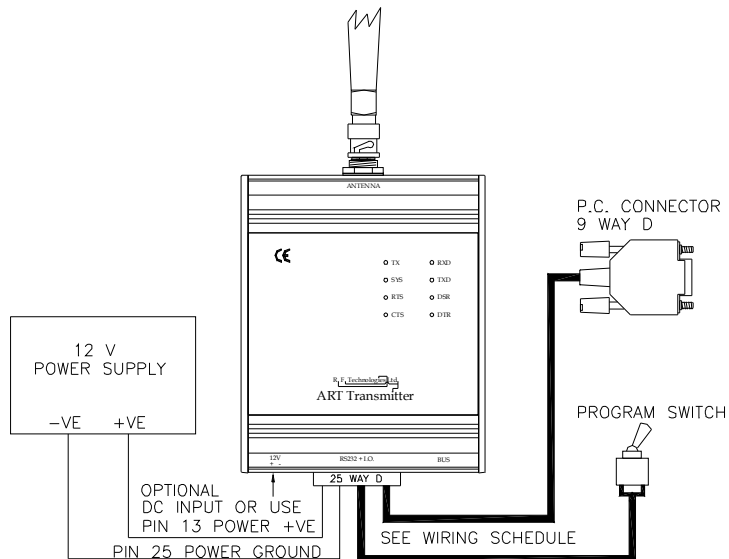

SIGNAL	FROM	TO
TXD	Transmitter 25 way "D" pin 2	PC 9 way "D" pin 3
RXD	Transmitter 25 way "D" pin 3	PC 9 way "D" pin 2
RTS (optional)	Transmitter 25 way "D" pin 4	PC 9 way "D" pin 7
CTS (optional)	Transmitter 25 way "D" pin 5	PC 9 way "D" pin 8
RS232 Ground	Transmitter 25 way "D" pin 7	PC 9 way "D" pin 5
Power supply ground	Transmitter 25 way "D" pin 25	Power supply -ve
Power supply +12V	Transmitter 25 way "D" pin 13	Power supply +ve
Test/Program enable	Transmitter 25 way "D" pin 9	Program switch N/O
Ground	Transmitter 25 way "D" pin 7	Program switch common

If desired additional connections and switches can be added to simulate other inputs such as the auto trigger inputs.

3 CONFIGURATION & TEST SOFTWARE (P4P)

Configuration of the paging transmitter is carried out using the "P4P" PC programme, this programme is also capable of performing some test routines with the transmitter. The paging transmitter should be connected to a suitable power supply and to comms port 1 of the PC, some means of shorting the test/program enable input to ground should also be provided to enable programming mode. A suitable cable is described in the "DEVELOPMENT/PROGRAMMING CABLE" section. Note that if test routines are to be run a suitable dummy load should be connected to the aerial socket. Before carrying out programming or test routines the program will check the version of the software in the transmitter to see if it is compatible, if not an error message will be giving stating the incompatibility, it is also possible that an error message may be given stating that the transmitter is not responding correctly, if this happens check that the test/program enable input has been shorted to ground. The set-up programme is supplied on a disc containing the main P4P.EXE file along with a defaults file "DEFAULTS.DAT" and a configuration file "RP.CFG", all three should be loaded to the working disc to be used. The programme is started by changing to the directory containing the programme, and typing "P4P", the display mode can be altered for different types of screens by typing "P4P /C" instead, a list of screen options is then given before the main program is entered, once set correctly the "/C" extension is no longer required in the command line and the program can be started normally.

3.1 OPENING MENU

Load the set-up program on the PC, the opening menu looks like this:

```
EDITING FILE 'NONAME'  
  
PROGRAM RADIO  
READ RADIO  
LOAD PROGRAM FROM DISC  
SAVE PROGRAM TO DISC  
EDIT PROGRAM  
ERASE PROGRAM  
TEST/CALIBRATE  
QUIT  
  
USE CURSOR KEYS TO MOVE AROUND SCREEN  
SELECT OPTIONS WITH ENTER KEY
```

Use the arrow keys to move around the options and hit enter to make a selection. The PROGRAM RADIO and READ RADIO options are used to load or read back the configuration from a transmitter, the configuration can be read from or saved to disc using the LOAD and SAVE options, QUIT exits the program, EDIT PROGRAM and TEST/CALIBRATE lead to further menus:

3.2 EDIT PROGRAM

The EDIT PROGRAM option leads to the main edit menu which looks like this;

```
EDITING FILE 'NONAME'

FREQUENCY RANGE (MHz)          U 425-475      EDIT DEFAULT CHANNEL DATA
                                U 425-475      EDIT AUTO TRIGGER CHANNEL 0
EXTERNAL LOGIC INPUT THRESHOLD +2.5V
TX TIMEOUT TIME (secs)         0             EDIT AUTO TRIGGER CHANNEL 1
SERIAL INTERFACE BAUD RATE     9600
USER SET POWER LEVEL (WATTS)   0.050

                                RETURN TO MAIN MENU

USE CURSOR KEYS TO MOVE AROUND SCREEN
SELECT OPTIONS WITH ENTER KEY
```

3.2.1 FREQUENCY RANGE

The frequency range may only be set to match the range of the pager transmitter you have. Note that altering this option will cause any frequency information already entered in the program to be lost.

3.2.2 EXTERNAL LOGIC INPUT THRESHOLD

This setting allows various logic level outputs from an external digital encoder to be catered for. It should be set such that the threshold is as close as possible to halfway between the logic 0 and logic 1 levels output from the encoder, for example if the encoder outputs 12V for a logic 1 and 0V for a logic 0 a setting of 5V (the nearest available setting to 6V) would be appropriate. Note that the sense of the signal can be inverted if required in the channel data menus, so don't worry at this stage about the sense of the signal.

3.2.3 TX TIMEOUT TIME

The TX timeout time is the maximum time that the transmitter will allow itself to stay keyed during a single transmission started by an external source, i.e. any external decoder or device connected to the serial port. It safeguards against channel blocking should an external device enter a fault condition. The timer can be disabled by selecting a value of 0 for the timeout time.

3.2.4 SERIAL INTERFACE BAUD RATE

The baud rate at which the serial port operates can be set anywhere between 150 and 9600 baud, it is strongly recommended that a speed higher than the radio signal baud rate is used.

3.2.5 USER SET POWER LEVEL

The transmit power levels in the channel menus are selected from a list of fixed values, these fixed values relate to power numbers used when controlling power from the serial port, if a power setting is required that does not appear in the list it can be entered as the USER SET POWER LEVEL, this can then be selected in the channel menus or as power number zero in serial port commands.

3.2.6 AUTO TRIGGER CHANNELS

Select either 2 or 4 auto trigger inputs. If 4 is selected, then the RTS and DTR lines are used as additional trigger inputs.

3.2.7 EDIT DEFAULT CHANNEL DATA/AUTO TRIGGER CHANNELS NUMBERS 0-3

These options lead to further menus allowing parameters for normal transmissions (default channel data) or those resulting from activation of the auto trigger inputs to be set. The default channel data is used when transmission is invoked by a device connected to the serial port or an external encoder. Note that most parameters can be changed under the control of the serial port if required and that these changes will apply for external encoders. In addition channel parameters may be individually set for each auto trigger input allowing each input to result in transmission on a different channel or even using a different modulation type or power level. Parameters for the auto trigger channels cannot be changed by using the serial port. The menus change in appearance depending on some parameter selections but the general look will be similar to this:

```
EDITING FILE 'NONAME'

EDITING AUTO TRIGGER CHANNEL 0          RETURN TO EDIT MENU

CHANNEL SPACING      12.5 kHz
TX FREQUENCY (MHz)  458.50000
RF OUTPUT POWER     0.25 W

MODULATION TYPE     POCSAG TEXT
BAUD RATE           1200
.....
NUMBER OF SYNC BYTES 72
PAGER ADDRESS       1234567
PAGER GROUP         A
STORED MESSAGE      >MESSAGE 0<

USE CURSOR KEYS TO MOVE AROUND SCREEN
SELECT OPTIONS WITH ENTER KEY
```

3.2.7.1 CHANNEL SPACING

The channel spacing selected decides the level of modulation applied to the radio signal, it must be set correctly to comply with the requirements of any regulated channel, note that altering the channel spacing also affects the transmit frequencies that may be entered, see "TX FREQUENCY".

3.2.7.2 TX FREQUENCY

The transmit frequency may be set to any channel in the set frequency range, note that if the channel spacing is set to 12.5kHz or 25kHz the frequency must be a multiple of 6.25kHz, if 20kHz spacing is used the frequency must be a multiple of 5kHz, make sure the correct spacing has been set before entering frequencies. The TX frequency for unused auto trigger channels should be set to 0 to disable them, the default channel data TX frequency may alternatively be set to 0 if the device is to be operated using only the auto trigger inputs.

3.2.7.3 RF OUTPUT POWER

The R.F. output power may be set to a number of values between 0.1 and 5.0 watts, alternatively the "USER" setting may be selected, see "USER SET POWER LEVEL".

3.2.7.4 MODULATION TYPE

Modulation type selects the transmission scheme to be used, altering the modulation type will cause some of the remaining options to alter, these are sub-parameters of the modulation type. Fewer modulation type options are available in the auto-trigger channel menus than in the default serial interface menu.

3.2.7.4.1 MODULATION TYPE - EXTERNAL

EXTERNAL modulation must be selected if an external encoder is used, this selection is only valid however in the default channel data menu, an external encoder cannot be used with the auto trigger inputs.

3.2.7.4.1.1 MODULATION TYPE - EXTERNAL - SENSE

An option is given for external modulation to be inverted, this only affects an external digital encoder input and not an analogue device.

3.2.7.4.2 MODULATION TYPE - POCSAG

This setting provides a low level (transparent) access to POCSAG transmission, it should only be used if the POCSAG TEXT or POCSAG NUMERIC options cannot be used, an intimate knowledge of the POCSAG protocol is required. It allows transmission of pocsag on a byte by byte basis, the controlling device must insert all sync, address and idle code words as required by the Pocsag specification, it must also generate all the CRCs, this is not necessary with the TEXT or NUMERIC options. This scheme does have the advantage that multiple address messages can be sent, and also that numeric and text messages may be mixed. This mode may not be used for the auto trigger inputs. For more detail on the POCSAG transmission scheme refer to "The book of the CCIR Radiopaging Code No.1" by the Radiopaging Code Standards Group

3.2.7.4.2.1 MODULATION TYPE - POCSAG - INTERNAL SYNC

If INTERNAL SYNC is switched on the bit reversals required at the start of a POCSAG transmission are generated by the transmitter, the controlling device may then start the transmit data at the first sync codeword. The last sync bit to be sent is a zero.

3.2.7.4.3 MODULATION TYPE - POCSAG TEXT

This setting allows a pocsag text transmission to be made simply by sending the pager address followed by the message text to the serial port. It also allows a stored message to be sent to a specific pager when used with the auto trigger inputs.

3.2.7.4.4 MODULATION TYPE - POCSAG - NUMERIC

This setting allows a pocsag numeric transmission to be made by sending the pager address followed by the message numerals to the serial port. It also allows a stored message to be sent to a specific pager when used with the auto trigger inputs.

3.2.7.4.5 MODULATION TYPE SC POCSAG

This mode allows compatibility with SCOPE products, the protocol allows the transmission of POCSAG text or numeric messages to a specified pager address using simple text based commands.(SCOPE is the registered trade mark of SCOPE ELECTRONICS Ltd.) Do not select this mode for the serial port if you also wish to use the digital inputs to activate stored messages, since the two modes are incompatible with each other.

3.2.7.4.6 MODULATION TYPE - SELCALL

The SELCALL option allows transmission to pagers or radios employing selective tone calling, several tone standards can be employed. Selcall can be used with the auto trigger inputs.

3.2.7.4.6.1 MODULATION TYPE - SELCALL - TONE STANDARD

The selcall tone standard defines the tone frequencies used, it must be set to match the standard used in the receiving device.

3.2.7.4.6.2 MODULATION TYPE - SELCALL - TONE LENGTH

This option sets the length of the selcall tone used. This is usually fixed according to the tone standard used although there are some variations.

3.2.7.5 POCSAG BAUD RATE

Either 512, 1200 or 2400 baud transmission data rate may be selected, this does not affect the baud rate at which the serial port runs.

3.2.7.6 POCSAG NUMBER OF SYNC BYTES

This field sets the number of sync bytes sent as preamble to any of the POCSAG modulation types, (for ordinary POCSAG mode INTERNAL SYNC must first be turned on), the POCSAG specification recommends transmission of 576 bits, this equates to 72 bytes.

3.2.7.7 PAGER ADDRESS

This option only applies to the auto trigger channels when POCSAG TEXT or POCSAG NUMERIC has been selected as a modulation type. The 7 digit decimal address of the pager to be called when the auto trigger input is activated should be entered here.

3.2.7.8 PAGER GROUP

Group A,B,C or D may be selected when POCSAG TEXT or POCSAG NUMERIC has been selected as a modulation type. The group will normally alter the type of beep emitted by the pager. The setting has the effect of altering the function bits within the transmitted pager address, for group A the function bits are 00, for B they are 01, for C they are 10 and for D they are 11. For more detail on this subject please refer to the standards relating to POCSAG transmission.

3.2.7.9 STORED MESSAGE

A stored message is required for the auto trigger channels to give the transmitter something to send when the auto trigger inputs are activated. If POCSAG TEXT mode is selected, a text message can be entered. If POCSAG NUMERIC mode is selected, numeric digits can be entered. Numeric pagers can only display the characters 0 to 9 and six others, these are the urgency indicator "U", a space, a hyphen "-", and the right and left square brackets "[" and "]", a spare character is also defined which may be sent by loading "S" in the message.

If SELCALL is selected, a string of selcall tones may be entered. Valid characters for selcall tones are 0 to 9 and A to F, F is a no tone character and causes quiet carrier for one tone period (tp), this is often required at the start of a transmission, also tones may be lengthened by repeating them, some pagers use a long first tone as a wake up tone. Note that repeat (E) tones are not inserted automatically by the pager transmitter. For example a message for a pager that requires a selcall sequence of 14332 with long first tone to activate it would be entered as 1111111143E2, the eight 1s lengthen the 1 tone to 8 x tp, the E tone is used to signal the repeated 3 (selcall decoders always want to see a change of tone for each digit, repeating the 3 would simply cause a long 3 tone and either be interpreted as a single 3 or rejected because of its tone length, four threes would thus be sent as 3E3E).

When configured for 2 input operation, the text, numeric or selcall strings can each be up to 80 characters long. When 4 input mode is selected, the length of each string is reduced to 40 characters.

3.3 TEST/CALIBRATE

The TEST/CALIBRATE menu offers test facilities. These tests should not normally be required but are described here for the benefit of service engineers with the necessary test equipment who wish to perform their own tests following a repair. The test routines will not run unless the test/program input on the transmitter is grounded.

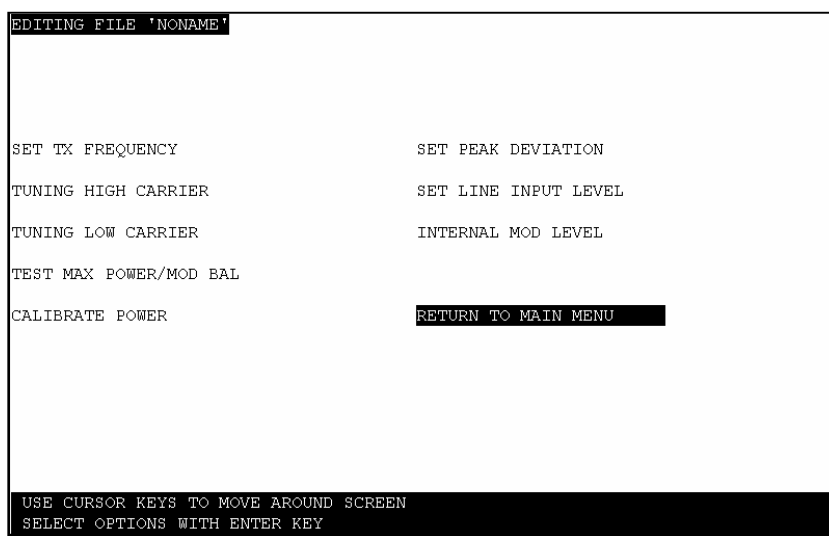

3.3.1 SET TX FREQUENCY

This option causes an unmodulated carrier to be generated at the centre frequency and power specified for the default channel, the centre frequency may then be electronically adjusted.

3.3.2 TUNING HIGH/LOW CARRIER

Tuning high/low carrier causes an unmodulated carrier to be produced at the power set in the default channel. High and low carrier cause the carrier to be offset by the modulation index used for Pocsag transmissions, the modulation index is decided by the channel spacing set in the default channel. For POCSAG this should be 25kHz and the modulation index should be 4.5kHz.

3.3.3 TEST MAX POWER/MOD BAL

This test is used to set the maximum power available from the transmitter using the trimpot in the transmitter module, and to check the balance of modulation applied to the TCXO and VCO in the transmitter, the balance is set using trimpots in the transmitter module to achieve the optimum quality 50Hz square wave modulated carrier.

3.3.4 CALIBRATE POWER

Calibrate power allows calibration of the selectable power levels on factory versions of the set-up program, on other versions the ability to store a calibrated power level is inhibited, the test can therefore only be used to check the power levels on these versions and not to set them. The test steps through the various power levels from 50mW to 5W, the option to increase or decrease the level is given, also to store, step to next, or quit. A new power level will not be remembered unless it is stored using the store command. The fast option forces the setting for the currently selected level to that of the previous level, this allows faster setting when eeprom memory is blank.

3.3.5 SET PEAK DEVIATION

This test allows external modulation to be applied in order to set the peak deviation implied by the channel spacing settings. The store option is inhibited on non-factory versions of the program and so the test can only be used to check settings on these versions. The test should be run with a 1kHz 2V r.m.s. signal applied to the AC modulation input.

3.3.6 SET LINE INPUT LEVEL

This option allows setting of the external analogue input level. The level should be adjusted to give the required deviation, the deviation will not exceed that set up in the SET PEAK DEVIATION test.

3.3.7 INTERNAL MOD LEVEL

Set internal mod allows calibration of the internal modulation levels implied by channel spacing settings. The store option is inhibited on non-factory versions of the program and so the test can only be used to check settings on these versions. Internal mod applies to all modulation types except external analogue. External digital modulation is intercepted by the microprocessor in the transmitter and re-generated as internal modulation.

4 EXAMPLES OF USE

There are three basic ways in which the transmitter can be used;

- a) using the auto trigger inputs to send stored messages
- b) using an external controller to transmit data using the serial port
- c) using an external encoder to provide the transmit audio/ data.

It is not necessary to restrict use to one of these methods, some may be used at the same time as others.

4.1 AUTO TRIGGER INPUTS

The transmitter has two digital inputs, these may be used as trigger inputs or as transmit enable inputs for external encoders. Programming the radio for external encoders disables the trigger input function.

Each of the trigger inputs can be used to trigger the transmission of a stored message on any frequency or format supported by the transmitter, the PC set-up program has a menu devoted to each of these lines to set up the message and other parameters. To operate the transmitter in this mode the only connections required are a 12V power supply, 1 or 2 trigger inputs and a ground return for those trigger inputs. Below is the hardware set-up required for an application using two trigger inputs:

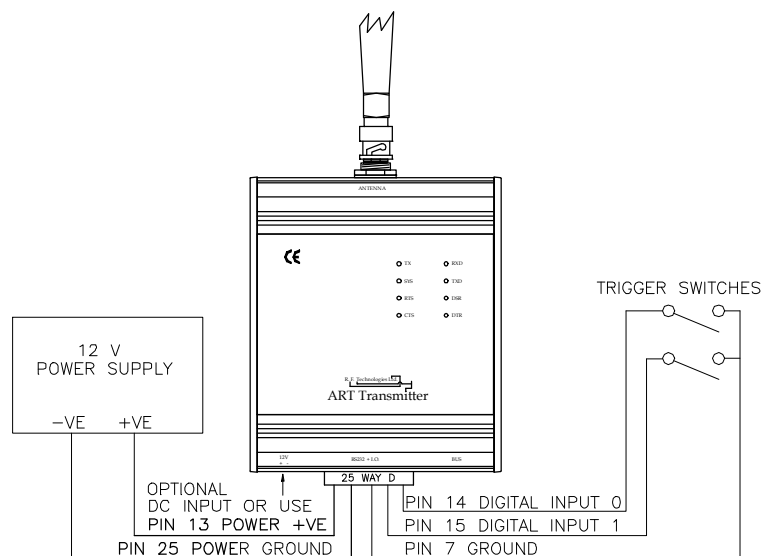

For the purpose of this example we shall say that trigger input 0 is to cause the text message "Alarm zone 23" to be sent to a 1200 baud Pocsag pager with the address 1234567, the pager's frequency is 466.075 MHz. Trigger input 1 is to cause the selcall tone sequence 54321 to be sent to a hand portable radio transceiver on 458.5 MHz, the radio uses the CCIR 70ms tone format.

The set-up program would be edited as follows:

The frequency range has been set to match the transmitter used, it must of course tie up with the transmit frequencies used. The rest of the items in the main edit menu are not relevant and have been left at their default values.

```

EDITING FILE 'NONAME'

FREQUENCY RANGE (MHz)          U 425-475      EDIT DEFAULT CHANNEL DATA
                                EDIT AUTO TRIGGER CHANNEL 0
EXTERNAL LOGIC INPUT THRESHOLD  +2.5V
TX TIMEOUT TIME (secs)         0             EDIT AUTO TRIGGER CHANNEL 1
SERIAL INTERFACE BAUD RATE     9600
USER SET POWER LEVEL (WATTS)   0.050

                                RETURN TO MAIN MENU

USE CURSOR KEYS TO MOVE AROUND SCREEN
SELECT OPTIONS WITH ENTER KEY

```

Auto trigger channel 0 is set up for the Pocsag pager.

```

EDITING FILE 'NONAME'

EDITING AUTO TRIGGER CHANNEL 0          RETURN TO EDIT MENU

CHANNEL SPACING      25 kHz
TX FREQUENCY (MHz)  466.07500
RF OUTPUT POWER     0.25 W

MODULATION TYPE     POCSAG TEXT
BAUD RATE           1200
.....
NUMBER OF SYNC BYTES 72
PAGER ADDRESS       1234567
PAGER GROUP         D
STORED MESSAGE      >Alarm Zone 23<

USE CURSOR KEYS TO MOVE AROUND SCREEN
SELECT OPTIONS WITH ENTER KEY

```

Auto trigger channel 1 is set up for the selcall radio, two "F" notones have been prefixed to the 54321 code to give a quiet carrier lead in delay of two tone periods ($2 \times 70\text{ms} = 140\text{ms}$)

The default channel menu has had its TX frequency set to 0 to disable it. The pager transmitter can now be programmed using a suitable programming lead

```
EDITING FILE 'NONAME'
EDITING AUTO TRIGGER CHANNEL 1          RETURN TO EDIT MENU
CHANNEL SPACING      12.5 kHz
TX FREQUENCY (MHz)  458.50000
RF OUTPUT POWER     0.25 W
MODULATION TYPE     SELCALL
TONE STANDARD       CCIR
TONE LENGTH         70ms
.....
.....
.....
STORED MESSAGE      >FF54321<
USE CURSOR KEYS TO MOVE AROUND SCREEN
SELECT OPTIONS WITH ENTER KEY
```

(see the section on PROGRAMMING).

When programming is complete power can be applied and shorting either of the trigger inputs will cause the appropriate message to be sent.

4.2 EXTERNAL ENCODERS

Two different types of external encoder can be used with the pager transmitter; those with analogue outputs and those with digital outputs. Two inputs are provided giving a choice of DC or AC coupled connection, DC coupling should be used for POCSAG signals where there is a strong DC component, however the signal must be centred around 2.5V or else a shift in the centre frequency of the transmission will result. If DC coupling is not possible try using digital mode, the threshold voltage (the voltage around which the signal is centred) is programmable, the processor looks to see if the input signal is above or below this threshold and then re-constitutes the signal internally. The threshold parameter is found in the main edit menu of the PC set-up program, a range of voltages can be selected, the voltage chosen should be approximately halfway between the logic 0 and logic 1 output voltage of the encoder, as a guide an encoder that uses 5V TTL compatible outputs will require a threshold of 2.5V, a device that uses RS232 compatible outputs (symmetrical positive and negative voltages between 3 and 15V) will require a threshold setting of 0V. It is also necessary to make sure that the sense of the signal is correct, that is that a logic 1 causes the correct change in the transmitted signal, the signal has the option of being inverted in the default channel data menu (this option only appears when modulation type external is selected), when set to normal a logic one causes a decrease in the radio carrier frequency (this is the same sense as required by the POCSAG specification), if inverted is selected the carrier frequency will rise for a logic one).

The mode of operation is decided by the transmit enable signal used, digital input 0 enables analogue transmission, digital input 1 enables digital mode.

It should be noted that the transmission path in analogue mode is not emphasised, i.e. it has a flat response characteristic. The transmitter should be programmed with the correct analogue input level when used with an external analogue encoder, this is done using the "SET LINE INPUT LEVEL" test in the "TEST/CALIBRATE" menu of the P4P set-up programme.

The only other connection required for the encoder is the transmit enable line, this line should be an open collector or volt free contact closing to ground when transmit is required. Connect the signal to digital input 0 for analogue operation or digital input 1 for digital operation.

For an external encoder to work the modulation type must be set to external in the default channel data menu of the PC set-up programme, if an external encoder is to work in conjunction with a controller connected to the serial port the controller must use the set modulation type command to select external before the external encoder can operate, the controller cannot then send transmit data or alter any other parameters (frequency, power etc.) until it has switched the modulation type back from external to an internal type.

This application example shows an analogue encoder connected to the transmitter.

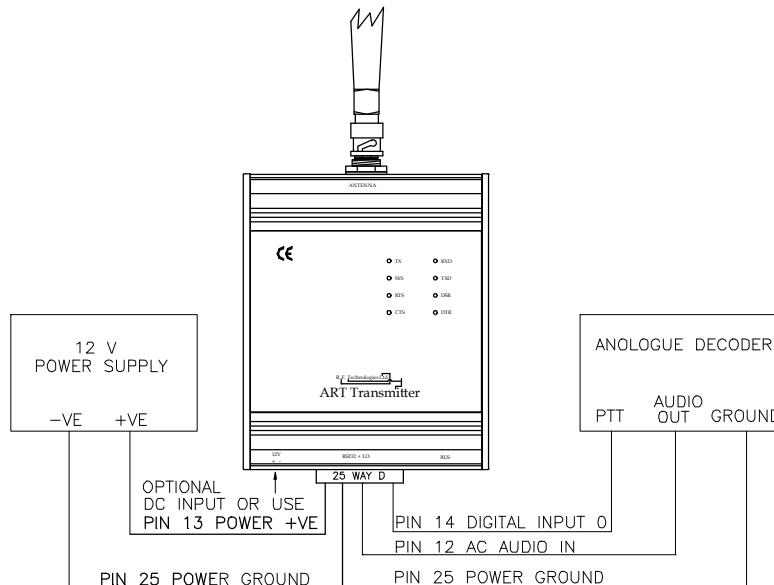

The transmitter would be set using the PC set-up programme as follows:

```

EDITING FILE 'NONAME'

EDITING DEFAULT CHANNEL DATA                                RETURN TO EDIT MENU
CHANNEL SPACING      12.5 kHz
TX FREQUENCY (MHz)  458.50000
RF OUTPUT POWER     0.25 W

MODULATION TYPE     EXTERNAL
LOGIC SENSE         NORMAL
.....
.....
.....
.....
.....
.....

USE CURSOR KEYS TO MOVE AROUND SCREEN
SELECT OPTIONS WITH ENTER KEY

```

The default channel data has been set for external modulation. The logic sense has been set to normal however this option only affects digital encoders.

Once all the programming and wiring up has been completed the system can be tested, the external encoder should then be able to key the transmitter and send data.

4.3 SERIAL PORT

The serial port provides the most extensive control of the paging transmitter. TXD and RXD are data lines, while RTS and CTS are handshake lines used to optionally control the flow of data. A typical set-up is shown here:

A P.C. is being used to control the transmitter here, the development cable described elsewhere in this manual could be used to replicate this set up (the test/program enable switch should be off). Note that RTS and CTS have been left disconnected as they are not necessary in most applications.

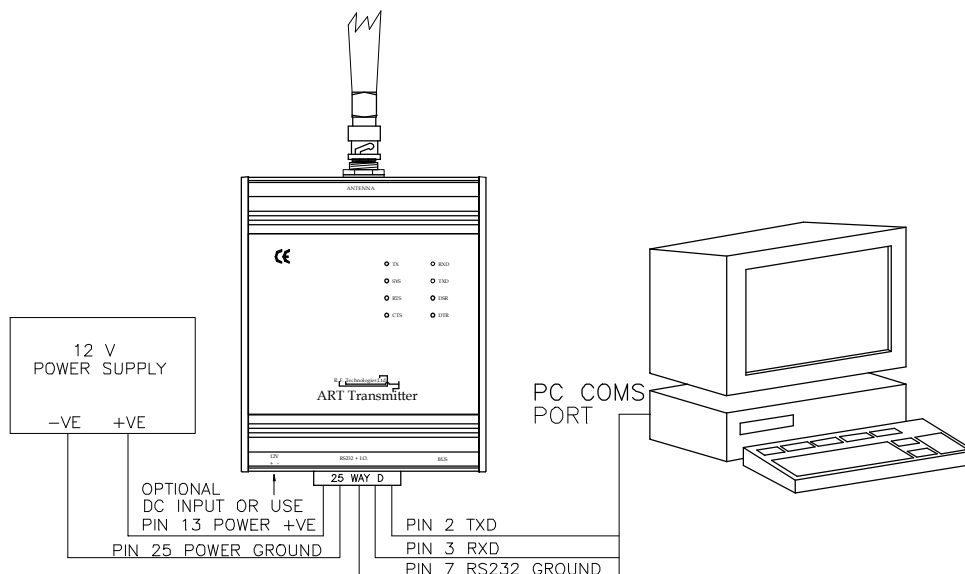

To illustrate this application a simple TURBO BASIC program will be used to send text to POCSAG pagers, the program will enable the pager's address and the text to be entered, transmission will then take place. The configuration entered in the paging transmitter would be as follows;

The default channel has been set up for POCSAG TEXT mode. The frequency of the pagers has been entered.

```

EDITING FILE 'NONAME'
EDITING DEFAULT CHANNEL DATA                                RETURN TO EDIT MENU
CHANNEL SPACING      25 kHz
TX FREQUENCY (MHz)  466.07500
RF OUTPUT POWER     0.25 W
MODULATION TYPE     POCSAG TEXT
BAUD RATE           1200
NUMBER OF SYNC BYTES 72
.....
.....
.....
USE CURSOR KEYS TO MOVE AROUND SCREEN
SELECT OPTIONS WITH ENTER KEY
    
```

The TURBO BASIC program is listed below:

```

CLS                                'CLEAR SCREEN AND OPEN
COMMODE$="COM1:9600,N,8,1,DS"      'THE COMMS PORT. DS
OPEN COMMODE$ AS 1                 'SUPPRESSES DSR/DTR.
START:                              'GET ADDRESS.
INPUT"PAGER ADDRESS OR Q TO QUIT";ADDRESS$
IF ADDRESS$="Q" THEN CLOSE:SYSTEM   'EXIT IF Q ENTERED.
INPUT"GROUP A,B,C OR D";GROUP$     'GET GROUP. APPEND TO
X=(VAL(ADDRESS$)*4)+ASC(GROUP$)-ASC("A") 'ADDRESS, CONVERT TO 6
XLO$=HEX$(X-(INT(X/4096))*4096)     'DIGIT HEX STRING.
XHI$=HEX$(INT(X/4096))              'HAS TO BE DONE IN TWO
WHILE LEN(XLO$)<3:XLO$="0"+XLO$:WEND 'STAGES SINCE BASIC
WHILE LEN(XHI$)<3:XHI$="0"+XHI$:WEND 'CANT DEAL WITH MORE
FORMADDR$=XHI$+XLO$                'THAN 4 DIGIT HEX.
INPUT"TEXT";TEXT$                  'GET TEXT.
FORMTEXT$=""                        'CONVERT THAT TO A HEX
FOR N=1 TO LEN(TEXT$)              'STRING REPRESENTATION
X$=HEX$(ASC(MID$(TEXT$,N,1)))       'OF THE ASCII CODES.
WHILE LEN(X$)<2:X$="0"+X$:WEND
FORMTEXT$=FORMTEXT$+X$
NEXT N                              'PRINT THE HEADER,
PRINT#1,"/";FORMADDR$;FORMTEXT$    'ADDRESS, AND TEXT TO
GOTO START                          'THE PAGER TRANSMITTER.

```

When the program is run it will first ask for the pager address, the decimal address should be entered, alternatively an upper case "Q" will cause the program to exit. Note that the program does not check to see if the address is legal, in a real application this should be done. It will then ask for the text message, if we enter 1234567 for the address and ABC for the data the resulting string sent to the pager transmitter will be /12D687414243 followed by a carriage return, the pager transmitter will accept this as a transmit command and send "ABC" to pager number 1234567. The protocol used by the pager transmitter for transmit and other commands is discussed in greater detail elsewhere in this manual.

5 SERIAL PORT PROTOCOL

The serial port protocol emulates the Communique CPT450 paging transmitter protocol (Communique UK Ltd is a registered trade mark of PACSCOM Ltd.). The radio is also able to emulate a protocol used by SCOPE (SCOPE is a registered trade mark of SCOPE Electronics Ltd.) by setting the modulation type to SC Pocsag.

5.1 SERIAL PORT AND HANDSHAKING

The pager transmitter's RS232 port employs a format of 9600 baud, 8 data bits, 1 start bit, and 1 stop bit, parity is not used. Data and control characters are all printables to allow easy viewing for debug purposes using a standard teletype programme. Flow control is provided using the CTS line however this can be ignored if maximum message sizes are adhered to. Data is never sent in both directions at once, the pager transmitter always responds to the controller with a message but not unless the message has been terminated correctly, similarly the controller is not allowed to send data to the transmitter while it is in the process of replying to an earlier message.

The serial input buffer has a size of 1024 bytes, the CTS handshake line will become inactive (signalling that the buffer is becoming full) when 768 bytes have been loaded and active again when less than 256 bytes are left. The 1024 byte buffer size is sufficient to load a Pocsag message of about 500 characters in Communique protocol which is far more than most pagers can cope with. Note that in SCOPE mode (Modulation type = SC Pocsag) messages containing more than 512 characters cause an error to be returned despite the fact that the serial input buffer is only half full, this is because the buffer used to format the message for transmission would overrun.

Two types of message can be sent to the transmitter; data for transmission, or control data, in either case the transmitter will respond when it has processed the message with an acknowledgement or requested data. The transmitter will not act upon data until the complete message has been input, it will then process the data, and reply to the controller. Until the reply has been received the controller may not send further data to the transmitter.

5.2 CONTROL CHARACTERS AND DATA FORMATS

All messages to the pager transmitter must be preceded with a type identification start character and terminated with a carriage return, similarly all messages from the pager transmitter to the controller will be preceded by a type identification start character and terminated with a carriage return. If the pager transmitter receives a second start character before a terminating carriage return is received it will abort processing of the previous message and restart a new one, a start character is thus a legal restart character. All start characters are in the range 20 hex to 2F hex, all data characters are 0 to 9 (30 to 39 hex) or upper case A to F (41 to 46 hex), characters in the range upper case G to Z (47 to 5A hex) are reserved as command type identifiers, the message termination character is always carriage return (0D hex).

Start characters are defined below:

character	hex	function	source
/	%2F	transmit data	controller
)	%29	control data	controller
(%28	control data	pager transmitter
*	%2A	acknowledge	pager transmitter
!	%21	error	pager transmitter

Control data may be sent in a number of ways, see the detailed descriptions of control commands for more information, in short the start character is followed by a text symbol identifying the type of control action required, numeric data may or may not follow and may be in either ascii-hex or decimal notation, the message is then terminated in a carriage return.

A summary of sample control messages that may be sent to the transmitter is shown below:

)F45028750cr	Set frequency 450.2875 MHz
)Fcr	request frequency
)S0cr	Set channel spacing 0 (12.5kHz)
)Scr	request channel spacing
)P3cr	Set power level 3
)Pcr	request power level
)M0121cr	Set modulation type 01 parameter 21
)Mcr	request modulation type
)Ccr	request compatibility number

cr = carriage return

When data is being requested (i.e. a read is being performed) the transmitter will reply with a message composed of its start character, the control type text character, the data, and a terminating carriage return. If a write is being performed only an acknowledgement character is returned.

Acknowledgements or command replies may be replaced by an error message if an error is detected, an error message starts with its own start character and is followed by a two digit hexadecimal field describing the error, the message terminates in the usual way with a carriage return. Error messages are never instigated by the pager transmitter, they are only sent in response to some message from the controller, and after that message's terminating carriage return

5.3 ERROR MESSAGES

Error codes follow the error message type identifier and are as follows;

01 - UNKNOWN CONTROL MESSAGE TYPE IDENTIFIER

The text character following the control data start character that identifies the message type is either unknown or inhibited in the current mode (test or normal mode).

02 - CONTROL MESSAGE TOO SHORT

The control message only contained the start and end characters.

03 - UNKNOWN START CHARACTER

A character with an ASCII code less than 2F hex was received and is not known as a legal start character.

04 - CONTROL MESSAGE TOO LONG

A control message was received that caused the serial input buffer to be filled was received. No control commands this long are legal.

06 - FREQUENCY OUT OF RANGE

A frequency setting command was received containing a frequency value that was out of the transmitter's range.

07 - INCORRECT NUMBER OF CHARACTERS IN DATA FIELD

A control command was received with the incorrect number of characters in the data field.

08 - CHANNEL SPACING SETTING OUT OF RANGE

A channel spacing setting command was received with an out of range value.

09 - POWER SETTING OUT OF RANGE

A power setting command was received with an out of range value.

0A - MODULATION TYPE SETTING UNKNOWN

An unknown modulation type setting was received. Note that the parameter byte will

always be accepted.

0C - COMMAND INHIBITED WHILE EXTERNAL MODULATION SELECTED

A command other than a change of modulation type was received while external modulation was selected, to execute other commands one of the internal modulation schemes must first be selected, this takes control away from a device connected to the external PTT lines.

0E - TEST MODE COMMAND UNKNOWN

An unknown command was received while in test mode. Test modes are for factory use only and not supported by this document.

0F - TEST PARAMETER UNKNOWN

An unknown parameter was passed in a test command. Test modes are for factory use only and not supported by this document.

10 - TEST ALREADY RUNNING

An attempt was made to select a test when a test was already running. Test modes are for factory use only and not supported by this document.

11 - TEST NUMBER TOO SHORT

A select test command was received with insufficient digits for the test number. Test modes are for factory use only and not supported by this document.

12 - AUTO TX INTERRUPT

An automatic transmission caused by one of the auto trigger lines interrupted the last message and the data has been lost.

13 - BUFFER OVERRUN/NULL MESSAGE

A terminating character was received with no preceding message or the buffer was overrun despite an attempt to stop data by making CTS invalid.

15 - MOD TYPE INVALID

An unknown modulation type was selected when transmission was attempted. This is probably due to corrupt EEPROM data.

17 - SCOPE MODE MESSAGE TOO SHORT

The transmit message passed in Scope mode was too short to be valid.

5.4 CONTROL MESSAGES - FREQUENCY

The frequency on which the pager transmitter operates may be set or read using this command, the frequency is written/read as 8 numeric decimal digits, the first three digits are the digits to the left of the decimal point of the frequency expressed in Megahertz, the last five are those to the right, the decimal point should not be sent, leading and trailing zeros should always be sent such that 8 numeric digits are always used and the position of the decimal point is maintained.

Examples are as follows;

function	controller message	transmitter reply
set frequency to 454.2 MHz)45420000cr	*cr
set frequency to 50.0125 MHz)05001250cr	*cr
read frequency)Fcr	(F0501250cr

5.5 CONTROL MESSAGES - CHANNEL SPACING

The channel spacing setting affects the modulation level used by the transmitter, the wider the channel the higher the level of modulation that may be used. Three settings to suit 12.5kHz, 20kHz and 25kHz channels may be selected, these are denoted as spacings 0, 1 and 2 respectively:

function	controller message	transmitter reply
set channel spacing 12.5kHz (spacing 0))S0cr	*cr
read spacing)Scr	(S0cr

5.6 CONTROL MESSAGES - POWER LEVEL

The transmitter output power level may be set using this command, nine factory preset power levels or one user preset power level may be selected.

function	controller message	transmitter reply
Set power level 4)P4cr	*cr
Read power)Pcr	(P4cr

Power levels are as follows;

level number	power
0	user variable 0-5W
1	0.1
2	0.25W
3	0.5W
4	0.75W
5	1W
6	2W
7	3W
8	4W
9	5W

5.7 CONTROL MESSAGES - MODULATION TYPE

The modulation type defines the signalling method used in the transmission, setting modulation type requires a two byte data field, the first byte sets the type, the second byte is used as a parameter field for that type, example commands are as follows;

function	controller message	transmitter reply
set modulation type 01 parameter 21)M0121cr	*cr
read mod type)Mcr	(M0121cr

The modulation types are listed below, for more detail on the data format for these types see the detailed explanations. Type 00 (external) does not use the transmitter's internal modulation

generator and so if selected the device will not be able to transmit any data sent to it via the RS232 port, instead the external modulation inputs are used and transmitter keying is achieved by use of the external data/analogue PTT lines. Note that if external modulation is selected all commands except the modulation type command become illegal, this command will override any transmission currently taking place.

Note also that if SC Pocsag (modulation type 04) is selected none of the serial port commands will work except those issued in the correct SC Pocsag protocol, it is possible to switch to SC Pocsag mode by changing the modulation type and then to escape back again in order to carry out serial port commands, see the section detailing this modulation type.

The parameter byte is represented by the second pair of ascii-hex digits in the command. Each data bit of the parameter byte may have different functions, unused bits should be set to 0.

Type 00 External Modulation

Parameter byte for External modulation

- Bit 0 0 = Normal Digital input (Analogue unaffected)
- 1 = Inverted Digital input (Analogue unaffected)
- Bit 1-7 Not used

Type 01 Pocsag

Parameter byte for Pocsag

- Bit 1,0 00 = 512 baud
- 01 = 1200 baud
- 10 = 2400 baud
- 11 = invalid
- Bit 2-3 Not used
- Bit 4 0 = Internal sync off
- 1 = Internal sync on
- Bit 5-7 Not used

Type 02 Pocsag Text

Type 03 Pocsag Numeric

Type 04 SC Pocsag

Parameter byte for Pocsag Text, Pocsag Numeric, SC Pocsag

- Bit 1,0 00 = 512 baud
- 01 = 1200 baud
- 10 = 2400 baud
- 11 = invalid
- Bit 2-7 Not used

Type 80 Selcall

Parameter byte for Selcall

Bit 0-2 Selcall tone standard as follows

- 000 = CCIR
- 001 = EEA
- 010 = EIA
- 011 = ZVEI
- 100 = ZVEIS
- 101 = ZVEID
- 110 = ZVEIP
- 111 as 110

Bit 4-5 Selcall tone length as follows

- 00 = 33ms

01 = 40ms
10 = 70ms
11 = 100ms

5.8 CONTROL MESSAGES - COMPATIBILITY NUMBER

The compatibility number may only be read and not written, a four digit decimal number is returned, the first two digits identify the software revision code in the pager transmitter, the second two digits are used to identify external controller programmes that are compatible with the transmitter. The first two numbers are updated whenever the pager transmitter code is altered, the second two numbers will only be altered if external programmes are affected, third party suppliers of external programmes should use the first pair of numbers to assess compatibility since the nature of changes will be unknown to them.

5.9 TRANSMIT DATA FORMATS

5.9.1 TRANSMIT DATA FORMAT - POCSAG EXTERNAL SYNC

The 512,1200 and 2400 baud versions of this modulation type use the same data format, the controller must send byte by byte the exact data to be transmitted on the air, this includes any synchronisation bits required. ASCII-hex notation is used in this mode in order to be able to pass binary data, i.e. using the characters 0-9 and A-F, thus a message that requires the transmission of 3AB567 hex in a mode requiring such a format would be sent as:

/3AB567cr (cr = carriage return 0D hex)

The most significant bit of each byte is sent first, and bytes in the order received.

5.9.2 TRANSMIT DATA FORMAT - POCSAG INTERNAL SYNC

This mode is the same as the external sync mode except that preamble bits as required by the CCIR radiopaging code number 1 are sent before the data loaded by the controller. The last sync bit sent is a zero. Note that the CCIR specification only requires 576 bits as a minimum however it is known that some pagers require more than this.

5.9.3 TRANSMIT DATA FORMAT - POCSAG TEXT

The 512, 1200, and 2400 baud versions of this modulation type use the same data format, the controller must send 6 bytes of address data in ASCII-hex, followed by a maximum of 508 characters of text in hex-hex. The address data needs to include the group, the group setting (denoted A,B,C or D) alters the type of beep emitted by the pager, the address is assembled as follows; we wish to send a message to a pager whose receive identity code is 1234567 (this number is usually written on the back of the pager), the group setting is to be C. 1234567 converts to 12D687 hex, shift this value left twice (the same as multiplying by 4), the result is 4B5A1C, the two lsb are now available for insertion of the group bits, for group A the bits should be 00, for B 01, C 10, and D 11 in binary. We want group C so the insertion of binary 10 into the two lsb of 4B5A1C hex results in 4B5A1E hex. Say that the message to be sent is "ABC", the characters "ABC" have the ASCII codes 41 hex, 42 hex and 43 hex, so the complete message is;

/4B5A1E414243cr

5.9.4 TRANSMIT DATA FORMAT - POCSAG NUMERIC

The 512, 1200 and 2400 baud versions of this modulation type use the same data format, the controller must send 6 bytes of address data in hex-hex, followed by a maximum of 508 characters of numeric data in ASCII-hex. The address data needs to include the group, the group setting (denoted A,B,C or D) alters the type of beep emitted by the pager, the address is assembled as follows; we wish to send a message to a pager whose receive identity code is 1234567 (this number is usually written on the back of the pager), the group setting is to be C. 1234567 converts to 12D687 hex, shift

this value left twice (the same as multiplying by 4), the result is 4B5A1C, the two lsb are now available for insertion of the group bits, for group A the bits should be 00, for B 01, C 10, and D 11 in binary. We want group C so the insertion of binary 10 into the two lsb of 4B5A1C hex results in 4B5A1E hex.

Numeric pagers use a 4 bit character set containing only 16 characters, these are;

hex code	character	hex code	character
00	0	08	8
01	1	09	9
02	2	0A	Spare
03	3	0B	U (urgency indicator)
04	4	0C	space
05	5	0D	- (hyphen)
06	6	0E] (right square bracket)
07	7	0F	[(left square bracket)

For example to send the message "123" the numerals "123" have the codes 01 hex, 02 hex and 03 hex, so the complete message is;

/4B5A1E010203cr

5.9.5 TRANSMIT DATA FORMAT - SC POCSAG

This mode emulates transmitters produced by SCOPE Electronics Ltd. When SC Pocsag is selected as a modulation type a different protocol is observed, none of the normal serial port commands will then operate except transmit data messages conforming to SCOPE protocol. The SCOPE protocol is the simplest transmit data message format to implement, and so to increase its power an escape sequence has been added to allow the user to switch out of SC Pocsag mode in order to carry out serial port commands. To do this the transmitter must be programmed to power up with any modulation type other than external or SC Pocsag, the serial port commands will then operate until a command is issued to change the modulation type to SC Pocsag, SCOPE protocol is then observed until the escape sequence is issued, the transmitter then loads the default modulation type stored in EEprom thereby re-enabling the serial port commands. If the default modulation type stored in EEprom is SC Pocsag the escape sequence has no effect and the transmitter will only understand SCOPE protocol transmit data messages.

The SC Pocsag transmit message format is as follows:

The message starts with the characters A or L for an alphanumeric pager, or N for a numeric pager, the 7 digit pager identity then follows, and after that the group code character A, B, C, or D to indicate the beep type, the message itself is then appended followed by a carriage return, a linefeed or an asterisk. So for example to send the message "hello" to alphanumeric pager 1234567 with a beep type B, send the following string:

"A1234567Bhello" followed by carriage return

To escape SC Pocsag mode enter either A, L, or N as if starting a normal transmit message but follow with Q and carriage return to quit:

"AQ" followed by carriage return

Note that the message start character (A, L, or N), the beep type character (A, B, C, or D) and the quit character (Q) must be upper case, but the message data can contain any characters except the termination characters (carriage return, linefeed, and asterisk).

5.9.6 TRANSMIT DATA FORMAT - SELCALL

In this mode the characters 0 to 9, and A to E are used to transmit selcall tones, a lead in delay or pause can be inserted by passing several "F" characters, this is translated as a "no tone" and will be transmitted as quiet carrier for one tone period. The repeat tone (normally E) is NOT inserted automatically, this allows tones to be extended for pagers requiring long wake up tones by sending the same tone several times, for example to transmit to such a pager whose number is 12345 the data "FF11111111112345F" will result in a two tone period lead in delay, a ten times extended "1" tone, normal 2, 3, 4 and 5 tones, and a one tone period lead out delay. Repeat tones (normally E) need to be used when digits are repeated in a sequence, for example a message for a pager that requires a selcall sequence of 14332 would be coded as 143E2, the E tone is used to signal the repeated 3 (selcall decoders always want to see a change of tone for each digit, repeating the 3 would simply cause a long 3 tone and either be interpreted as a single 3 or rejected because of its tone length, four threes would thus be sent as 3E3E). The above examples must all be preceded with the transmit data message prefix forward slash "/" and terminated with a carriage return when sent to the transmitter.

RF DataTech
is a trading division of:-

R.F. Technologies Ltd
27 - 29 New Road
Hextable
Kent BR8 7LS

Tel: +44 (0) 1322 614 313
Fax: +44 (0) 1322 614 289

E-Mail: info@rfdatatech.co.uk

ADDITIONAL PRODUCT DATA
www.rfdatatech.co.uk